

Enrouleurs automatiques haute-pression

SoST 14 / SoST 20

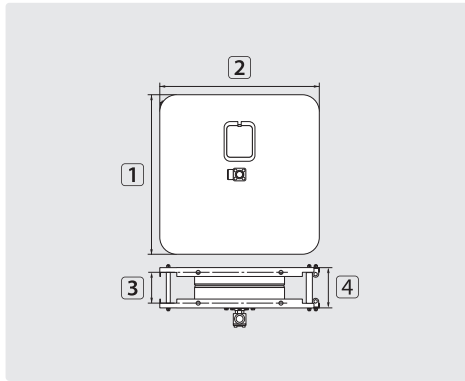

TYP	extérieur	Ø = tuyau	↔
01	15,0 mm	= 14 m	
02	15,0 mm	= 20 m	

Acier thermolaqué. Convient pour zone abritée

R+M Nr.	★	Ⓒ	Ⓔ	DN	P	°C	Ⓓ	1	2	3	4	TYP
740 002	●	3/8" F	1/2" F	10	400 bar	90 °C	14,0 kg	470 mm	470 mm	107 mm	135 mm	01
740 005	●	3/8" F	1/2" F	10	400 bar	90 °C	16,0 kg	470 mm	470 mm	167 mm	195 mm	02

SoST 14 / SoST 20

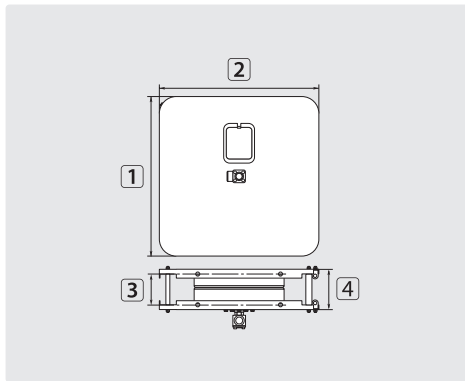

TYP	extérieur	Ø = tuyau	↔
01	15,0 mm	= 14 m	
02	15,0 mm	= 20 m	

Inox AISI 304. Convient pour zone non abritée

R+M Nr.	★	Ⓒ	Ⓔ	DN	P	°C	Ⓓ	1	2	3	4	TYP
740 008	●	3/8" F	1/2" F	10	400 bar	90 °C	14,0 kg	470 mm	470 mm	107 mm	135 mm	01
740 009	●	3/8" F	1/2" F	10	400 bar	90 °C	16,0 kg	470 mm	470 mm	167 mm	195 mm	02